

S O U N D P R O J E C T S

PRODUCT INFORMATION
SP3 SATELLITE SYSTEM



SOUND PROJECTS
Jonkerweg 17-19
1217 PM Hilversum
The Netherlands
Phone +31 (0)35 6213233
Fax +31 (0)35 6215455

SP3 SATELLITE SYSTEM

The **SOUND PROJECTS 3 Satellite System** is a specialised addition to the SOUND PROJECTS series of self-powered arrayable sound reinforcement.

The advantages of **self-powered** system design are constantly employed (already since 1986) to achieve maximum efficiency through optimal cooperation of the different components, e.g. speakers, horns, filters electronics.

Ease of use and ergonomics are key features in all SOUND PROJECTS designs. Only real necessities are employed in a SP system. No gimmicks. True PLUG AND PLAY without crash sensitive hardware, often found in digital equipment. Minimal cabling, no complimentary control units, and virtually no equalising are necessary.

The **SP3 Satellite system** consists of a midbass host system, the **SP3 M**, and three different top cabinets, differing in loudness and/or throw. Together with the accompanying subwoofers, the **SP2-15** or **SP3-15**, this system is capable of generating tremendous SPL in both medium and large sized configurations.

The satellites **SP2-85T**, **SP3-85T** and **SP3-45T** cover the mid and high band with the same precise, musically matched horn-loaded 10-inch and 1.5-inch compression drivers as found in the SP4 Diamond.

The **SP3-85T** and **SP3-45T** employ two drivers on proprietary twin-drive throats with a joint aperture for the high frequencies. Individual amplifier power and the appropriate protection and correction is provided by the host **SP3 M** system.

The **SP3 M** features a 15-inch driver loaded by a low-compression horn and covers the low-mid frequencies. It also holds the power-amp sections for the top satellites. The system allows stacking and arraying in any configuration both horizontally and vertically. One SP3 Top is

combined with up to two **SP3 M's** to make an extremely powerful long- or wide-throw system. Likewise one **SP2-85T** together with one **SP3 M** makes a very compact and slim stack. Splitting the low-mid band allows the sound-system designer virtually unlimited variations to combine **SP3 M's** and the satellites to realise the desired power response, coverage pattern and linear power matching. Another practical advantage of the SOUND PROJECTS Satellite Series is that short, medium and long throw models including sub-lows are designed to work together phase-coherently and power-matched.

The **flying hardware** of the SP3, **Quick-rig™**, is designed in compliance with the German BGV C1 rules for the prevention of accidents. (see **Quick-rig™** documentation for details).

Master Blaster's philosophy to provide systems with virtually flat frequency response enables the sound engineer to create his/her specific sound with a minimal effort. For most programme material the power balance between one **SP2-85T**, an **SP3 M**, and one **SP3-15** sub-low will be just right, although in single stack set-ups one could prefer to use double bass cabinets. Apart from taste this is of course largely dependent on programme and venue.

To guarantee maximum reliability and noiseless (hiss free) operation each driver of the SP3 satellite system is powered by its dedicated 600W MA4 power amplifier. This unique and proprietary design is an integrated combination of amplifier, filter section and protection circuitry.

The **SP-215** and **SP3-15** are port loaded sub-low designs incorporating two and three of our proprietary 15" long excursion drivers respectively that can make the same volume displacement as 21" drivers and yet generate the punch of a 15".

MA4 POWER AMPLIFIER CONTROL MODULE

MA4 power amplifier control module

The MA4 power amplifier module incorporates power supplies for the controllers and MA4 electronics, soft power up, filter sections, three or four amplifiers (product dependent) and protection circuitry. The integral network of these different sections are designed to perform with minimal number of components yet acquiring the highest efficiency.

The step-less speed silent fan cooler avoids unwanted cooling noises to the limit.

The amplifier module is available in different mains voltages (100V, 115V, 230V)

Signal conditioning

The DALC (Dual Audio-logic Level Control) audio processing unit of the MA4 power amplifier module incorporates multiple analogue VCA techniques with high accuracy, headroom and dynamic range. The DALC is a dual operating RMS based gain riding circuit which maintains the tonal balance of the sound as perceived by the human ear, even at very high levels. Filter peaking, which could limit headroom and often encountered with commonly used feedback-filters, is avoided through use of constant-Q filter sections.

MA4 power amplifiers

The multiple channel amplifiers in the MA4 module is a low feedback, low distortion design with overheating protection. It reveals good stability upon spontaneous loads along with excellent protection handling of fast rise time signals and excessive signal conditions.

Power Supply Unit

The PSU of the MA4 power amplifier module comes with soft power up, to enable multiple cabinet switch-on's at once without excessive transformer inrush current.

When an over voltage is detected the mains input will automatically be shortcut (high-voltage clamping) to make sure the outside mains fuse (for instance from a generator) detects the problem, and shuts down.

Controls and connectors

Mains power LED indicator (Green)

Signal present LED indicator (Yellow)

LF protection active (Red)

HF protection active (Red)

Input 3 pin XLR (female), balanced

Signal thru XLR (male)

Protection circuits:

- * Mains inrush current limiter

- * Over-voltage protection

- * Self resetting over temperature protection

- * Temp. and signal dependent DC fan

- * Speaker overheating and fusing current protection

- * Delayed speaker switch-on

Data SP3 M

Amplifier(s): 1x MA4-technology

RMS output:

1 x 600W @ 4 ohms

Frequency response (-3dB): 80 Hz - 315kHz

Max. SPL continuous: 134dB@1m

Calculated peak/long-term: 137dB@1m

Coverage angle: Configuration Dependent

Drivers: 15"

Transient output: 600W

Crossover 4th order: -

Low-pass 4th order: -

Filter subsonic: 80Hz, 4th order

Filter ultrasonic: 20.000Hz 1st order

Mains voltage: 210 - 240V (50/60 Hz)

100 V, 110 V optional

Data SP2-85T

Amplifier(s): 2x MA4-technology

RMS output:

2 x 300W @ 8 ohms

Frequency response (-3dB): 315 Hz – 20 kHz

Max. SPL continuous: 134dB@1m

Calculated peak/longterm: 137dB@1m

Coverage angle: 85H x 30V

Drivers: 10" / 1.5"

Transient output: 500W

Crossover 4th order: 2300 Hz

Low-pass 4th order: -

Filter subsonic: 320 Hz, 4th order

Filter ultrasonic: 20 kHz, 1st order

Mains voltage: 210 - 240V (50/60 Hz)

100V, 110V optional

THE SP3M LOUDSPEAKER

THE SP2-85T LOUDSPEAKER

SP3M loudspeaker

The SP3M features a 15-inch driver loaded by a low-compression horn and covers low-mid frequencies. It also holds the power-amp sections for the top satellites. The system allows stacking and arraying in any configuration both horizontally and vertically.

The enclosure is constructed of 13-layer 'ecoplex' (poplar) plywood and is covered with sturdy industrial automotive carpet.

SP2-85T loudspeaker

The SP2-85T loudspeaker cabinet is a high/mid, two-way fully horn-loaded enclosure holding one 10" Mid drivers on a proprietary horn, and one 1.5" HF drivers on a CD horn that optimises the air load and smoothly blends the radiation pattern of the two transducers.

With a coverage angle of 85 degrees horizontally and 30 degrees vertically ultra high SPL is realized. Consequentially a longer 'throw' can be achieved since our proprietary and proven horn designs endows the SP2-85T with the perfect combination of efficiency and radiation pattern control.

The enclosure is constructed of 13-layer 'ecoplex' (poplar) plywood and is covered with sturdy industrial automotive carpet.

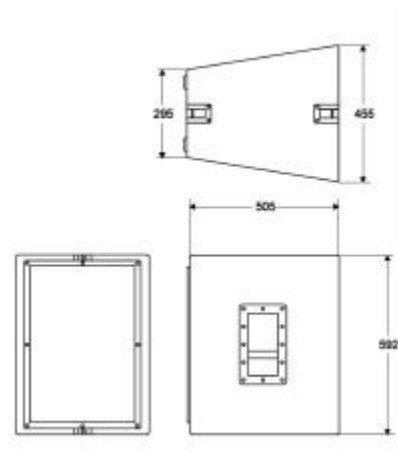
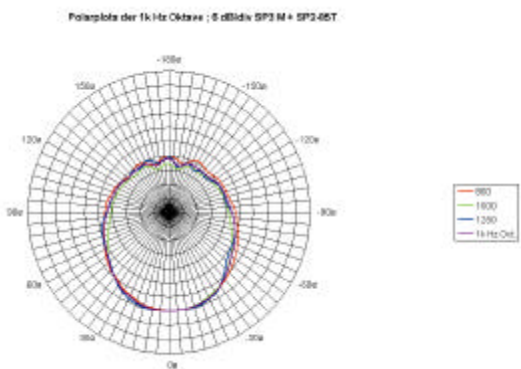
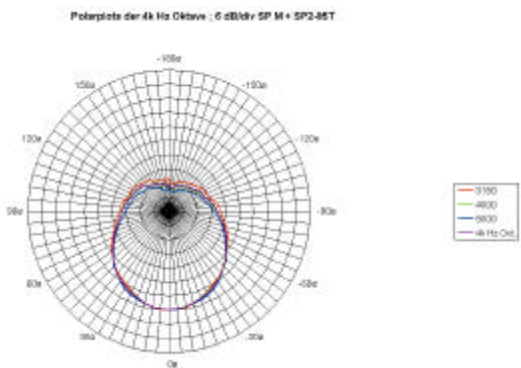
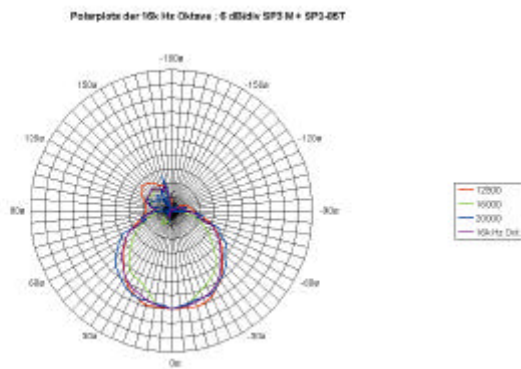

SP2-85T, cabinet dimensions in mm.

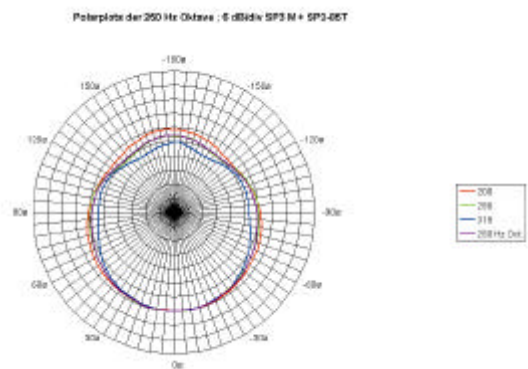

THE SP3-45T LOUDSPEAKER

THE SP3-85T LOUDSPEAKER

SP3-45T loudspeaker

The SP3-45T loudspeaker cabinet is a high/mid, two-way fully horn-loaded enclosure holding two 10" Mid drivers on proprietary horns, and two 1.5" HF drivers combined on a proprietary twin-drive with joint aperture on a CD horn that optimises the air load and smoothly blends the radiation pattern of the two transducers. With a coverage angle of 45 degrees horizontally and 30 degrees vertically ultra high SPL is realized. Consequentially a longer 'throw' can be achieved since our proprietary and proven horn designs endows the SP3-45T with the perfect combination of efficiency and radiation pattern control.

The enclosure is constructed of 13-layer 'ecoplex' (poplar) plywood and is covered with sturdy industrial automotive carpet.

SP3-85T loudspeaker

Like the SP3-45T the SP3-85T is housed in the standardised SP3 top enclosure.

Fitted with two 10" Mid drivers on proprietary horns, and two 1.5" HF drivers combined on a proprietary twin-drive with joint aperture on a CD horn. With a coverage angle of 85 degrees horizontally and 30 degrees vertically ultra high SPL is realized.

Using the same component drivers as the SP3-45T, but with a slightly enlarged horizontal dispersion angle it is used for medium-throw purposes.

The enclosure is constructed of 13-layer 'ecoplex' (poplar) plywood and is covered with sturdy industrial automotive carpet.

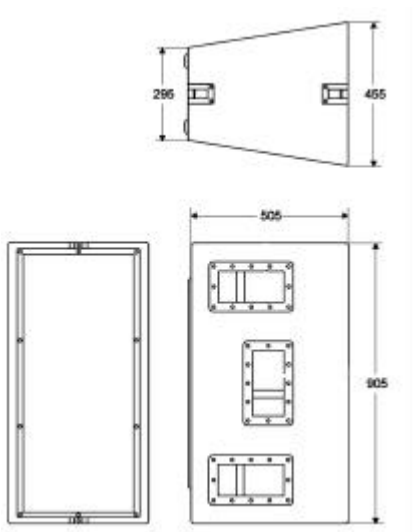

SP3M, SP3-45T and SP3-85T, cabinet dimensions in mm.

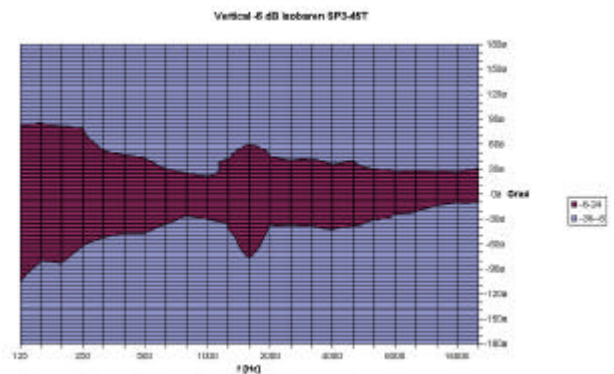
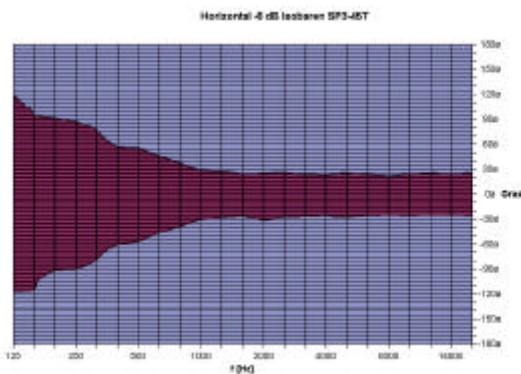

QUICK-RIG™ FLYING HARDWARE

The SP3 enclosure comes with Quick-rig™ cabinet hardware. The Quick-rig™ flying system provides numerous rigging possibilities. The proprietary flying system can hold up to 360 kg (6 SP3 cabinets or up to 10 SP2 in a column), with a safety factor of 10. The truss-module allows SP2 and SP3 cabinets to be flown as a single or multiple column array. When used as a single column array the truss-module is accommodated with a 5T shackle to provide connection with lifting gear. Positioning the shackle to the back of the truss-module will slant the array to the front.

The Connecting Bar is used for those situations where more than one column is needed. Two types of connecting bars are available. The 18-

degree version for waved front configurations and the 0-degree version for flat front situations. The Q-pin is the brain behind the Quick-rig™ system, because only one connection per cabinet is needed. It is used for truss module-to-cabinet and cabinet-to-cabinet connection. Easy handling evidently shortens build-up times and can be done by just one person.

After positioning of the truss-module or cabinet on top of another cabinet the Q-pin is pushed through the cabinet hardware from the front to the back of the cabinet(s). At the backside the two legs of the pin will stick out just enough for the Q-pin block to slide over. Two locking pins, one for each leg, avoid the Q-pin block to slide back.



Top view of three arrays with 18-degree truss-to-truss connecting bars.



Top view of three arrays with 0-degree truss-to-truss connecting bars.

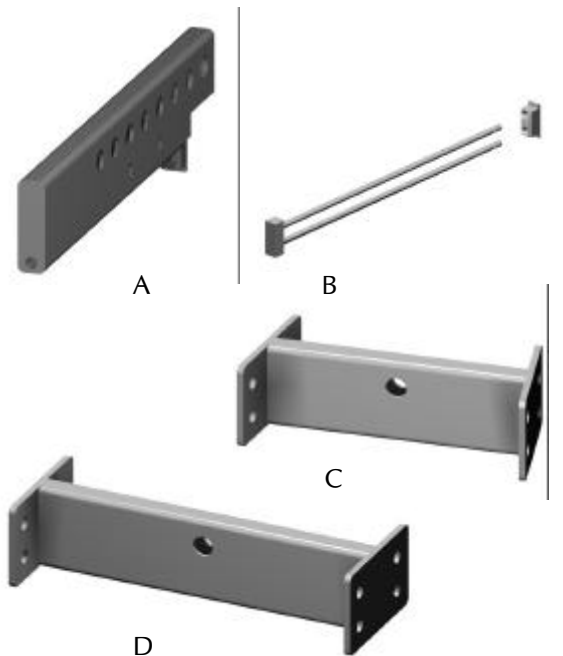

Quick-rig™ flying hardware. Trussmodule[A], Q-pin[B], Trussconnector 18-degrees[C] and 0-degrees[D].



Quick-rig™ flying example.